

BINKS[®]

Instruction Manual

DRX Ram Unit Outfits

- **DRX60 – Ø160mm Dual Post**
- **DRX205 – Ø160mm Dual Post**

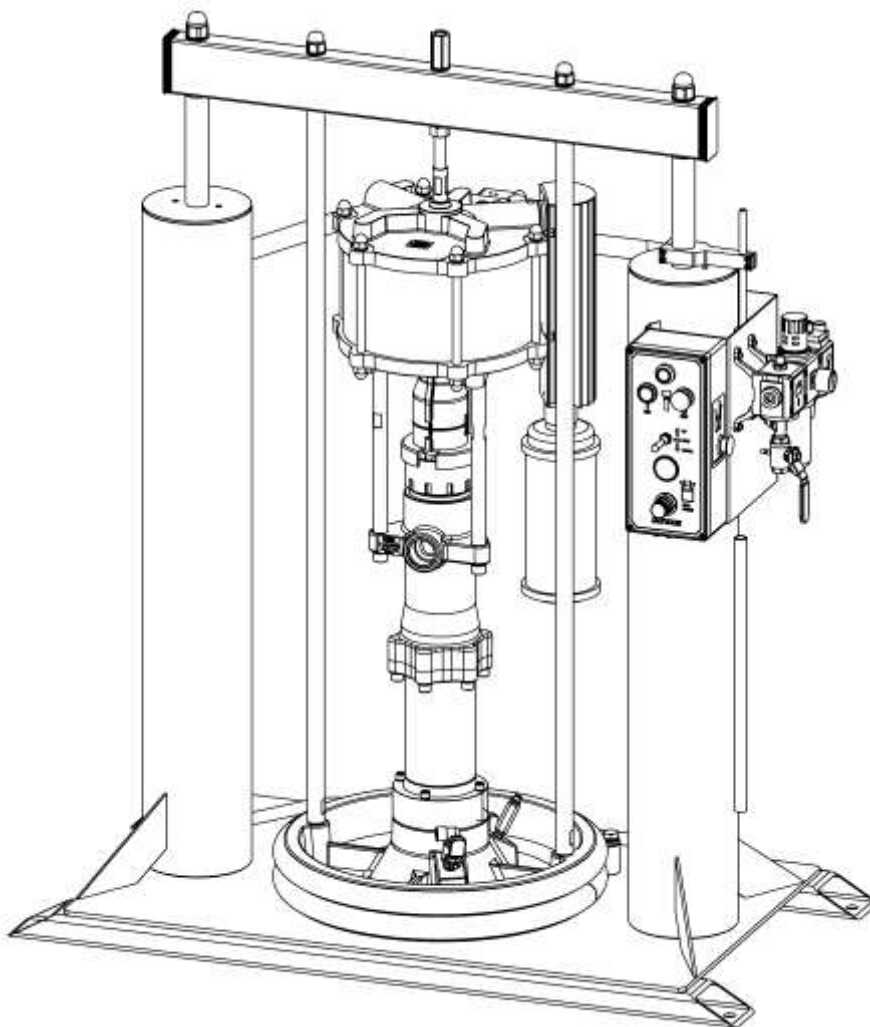

Finishing Brands.

A **CARLISLE** COMPANY

Product Description

104156, 104157.

This product is designed for use with:

Solvent and Water based Materials

Manufacturer:

Finishing Brands UK Ltd.,
Ringwood Road,
Bournemouth, BH11 9LH, UK

EU Declaration of Conformity



We: Binks declare that the above product conforms with the Provisions of:
Machinery Directive 2006/42/CE

by complying with the following statutory documents and harmonized standards :

EN ISO 12100: Safety of Machinery – General Principles for Design

EN ISO 4414: Pneumatic Fluid Power – General Rules and safety requirements

EN 12621: Machinery for the supply and circulation of coating materials under pressure – Safety requirements

Providing all conditions of safe use stated within the product manuals have been complied with and that the final equipment into which this product is installed has been re-assessed as required, in accordance with the essential health and safety requirements of the above standards, directives and statutory instruments and also installed in accordance with any applicable local codes of practice.

D. Smith (General Manager)
31/03/2015

Table of Contents

Warnings	4
Specification	6
General Description	7
Model Selection	8
DRX60	10
Installation	10
Operation Instructions	11
Setting up Ram Trip Valve	11
Setting Up Ram Pressure	11
Lowering Ram Onto Material	12
Rising Ram From Drum	12
Parts List	13
Ram Assembly Drawings	17
DRX205	18
Installation	18
Parts List	19
Ram Assembly Drawings	21
104097 Ram Control Box	22
104098 Air Regulator Unit	23
104160 Trip Rod Assembly	24
194461 Ram Plate 60L / 15G	25
194295 Ram Plate 205L / 55G	26
Accessories	27
Spare Parts	28
Cylinder Service Reference	39



WARNING

Directions for Working Safety

This Product has been constructed according to advanced technological standards and is operationally reliable. Damage may, however, result if it is used incorrectly by untrained persons or used for purposes other than those for which it was constructed.

The locally current regulations for safety and prevention of accidents are valid for the operation of this product under all circumstances. International, national and company safety regulations are to be observed for the installation and operation of this product, as well as the

procedures involved in maintenance, repairs and cleaning.

These instructions are intended to be read, understood and observed in all points by those responsible for this product. These operating and maintenance instructions are intended to ensure trouble free operation. Therefore, it is recommended to read these instructions carefully before start-up. Binks PCE cannot be held responsible for damage or malfunctions resulting from the non-observance of the operating instructions. These instructions, including regulations and technical drawings, may not be copied, distributed, used for commercial purposes or given to others either in full or in part without the consent of Binks PCE.

We reserve the right to alter drawings and specifications necessary for the technical improvement of this product without notice.



Equipment Misuse Hazard

Equipment misuse can cause the equipment to rupture or malfunction and result in serious injury.

- This equipment is for professional use only.
- Read all instruction manuals, tags, and labels before operating the equipment.
- Use the equipment only for its intended purpose.
- Do not alter or modify this equipment. Use only genuine Binks PCE parts and accessories.
- Check equipment daily. Repair or replace worn or damaged parts immediately.
- Do not exceed the maximum working pressure stated on the equipment or in the Technical Data for your equipment. Do not exceed the maximum working pressure of the lowest rated component in your system.
- Use fluids and solvents which are compatible with the equipment wetted parts. Refer to the Technical Data section of all equipment manuals. Read the fluid and solvent manufacturer's warnings.
- Route hoses away from traffic areas, sharp edges, moving parts, and hot surfaces. Do not expose hoses to temperatures above 82°C (180°F) or below -40°C (-40°F).
- Do not lift pressurized equipment.
- Comply with all applicable local, state, and national fire, electrical, and safety regulations.



Fire, Explosion and Electric Shock Hazard

Improper grounding, poor ventilation, open flames or sparks can cause a hazardous condition and result in a fire, explosion, or electric shock.

When installed and operated in accordance with its instructions, the pump is approved for operation in Zone 1 (Europe) & Division 1 (North America), hazardous locations. (ATEX Cat 2)

- Electrical equipment must be installed, operated, and serviced only by trained, qualified personnel who fully understand the requirements stated in this instruction manual.
- Ground the equipment and all other electrically conductive objects in the spray area. After grounding test with ohmmeter to ensure earth continuity is 1 ohm or less.
- Keep all covers tight while the motor is energized.
- If there is any static sparking or you feel an electric shock while using this equipment, stop spraying/dispensing immediately. Do not use the equipment until you identify and correct the problem.
- Provide fresh air ventilation to avoid the build up of flammable fumes from solvents or the fluid being pumped.
- Keep the pumping area free of debris, including solvent, rags, and gasoline.
- Electrically disconnect all equipment in the pumping area.
- Extinguish all open flames or pilot lights in the spray/dispense area.
- Do not smoke in the spray/dispense area.
- Do not turn on or off any light switch in the spray/dispense area while operating or if fumes are present.





WARNING



READ THE MANUAL

Before operating equipment, read and understand all safety, operation and maintenance information provided in the operation manual.



PROP 65 WARNING

WARNING: This product contains chemicals known to the State of California to cause cancer and birth defects or other reproductive harm.



DE-ENERGIZE, DEPRESSURIZE, DISCONNECT AND LOCK OUT ALL POWER SOURCES DURING MAINTENANCE

Failure to De-energize, disconnect and lock out all power supplies before performing equipment maintenance could cause serious injury or death.



HIGH PRESSURE CONSIDERATION

High pressure can cause serious injury. Relieve all pressure before servicing. Hose leaks, or ruptured components can inject fluid into your body and cause extremely serious injury.



OPERATOR TRAINING

All personnel must be trained before operating equipment.



KNOW WHERE AND HOW TO SHUT OFF THE EQUIPMENT IN CASE OF AN EMERGENCY



KEEP EQUIPMENT GUARDS IN PLACE

Do not operate the equipment if the safety devices have been removed.



NOISE HAZARD

You may be injured by loud noise. Hearing protection may be required when using this equipment.

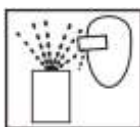

PROJECTILE HAZARD

You may be injured by venting liquids or gases that are released under pressure, or flying debris.



AUTOMATIC EQUIPMENT

Automatic equipment may start suddenly without warning.



PINCH POINT HAZARD

Moving parts can crush and cut. Pinch points are basically any areas where there are moving parts.



WEAR SAFETY GLASSES

Failure to wear safety glasses with side shields could result in serious eye injury or blindness



MAGNETIC FIELD PRESENT

You may be subjected to magnetic fields which may interfere with the operation of certain pacemakers.

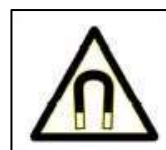

MAGNET HAZARD

Take care when handling magnets. Avoid getting magnets in close proximity of each other. Injury or damage to magnets may result.

Specification			
Feature			Remarks
Down thrust at 6 bar air pressure	DRX60	22.6 KN / 5080 lbf	
	DRX205	22.6 KN / 5080 lbf	
Maximum Working Air Pressure		7 Bar / 101 psi	
Air Inlet		1/2" BSP F	
Air Quality		ISO 8573-1 Class 5/5/4	Dirt 40 Microns Water +7°C @ 7 Bar Oil 25mg/m ³
Ram Stroke	DRX60	700 mm / 28"	
	DRX205	960 mm / 38"	
Unit Height - Fully Extended	DRX60	2180 mm / 86"	Including Pump
	DRX205	2625 mm / 103.5" max.	Including Pump
Wiper Ring Material	DRX60	EPDM	
	DRX205		
Weight without Pump	DRX60	254 Kg / 560 lbs	
	DRX205	380 Kg / 836 lbs	
Drum pressure at 6 bar air	DRX60	2.2 Bar / 32 psi	Ensure container can withstand these pressures before use.
	DRX205	0.9 Bar / 13 psi	

General Description

Ram Unit Outfits are designed to ensure correct 'priming' of the pump fluid section inlet and to prevent 'cavitation' when high viscosity materials are pumped. The Ram units will accommodate industry standard barrels of 60 & 205L.

The outfits comprise of Ram Unit, Pump and Follower plate assembly. The Follower plate is designed to accept both chop check or ball check pumps

The Ram plate has two seals, which accurately fit the inside of the barrel, as material is used the ram plate descends, cleaning the sides of the barrel, reducing wastage to a minimum.

A pneumatic control box (see page 26) with necessary Ram control features

- Raise and lower the ram plate
- A 'release valve to separate the ram from the empty container.
- Air pressure regulator to control Downforce pressure
- Pump Stop / Start

A height adjustable trip valve assembly (see page 28) is also included as standard to stop the pump when the bottom of the container is reached.

The pump air regulator unit (see page 27) is supplied with hose connection to the air motor.

An option is available to provide automatic 'changeover' when using two Ram Units in Duty / Standby mode.

Model Selection

Ram Unit Outfit Selection Guide

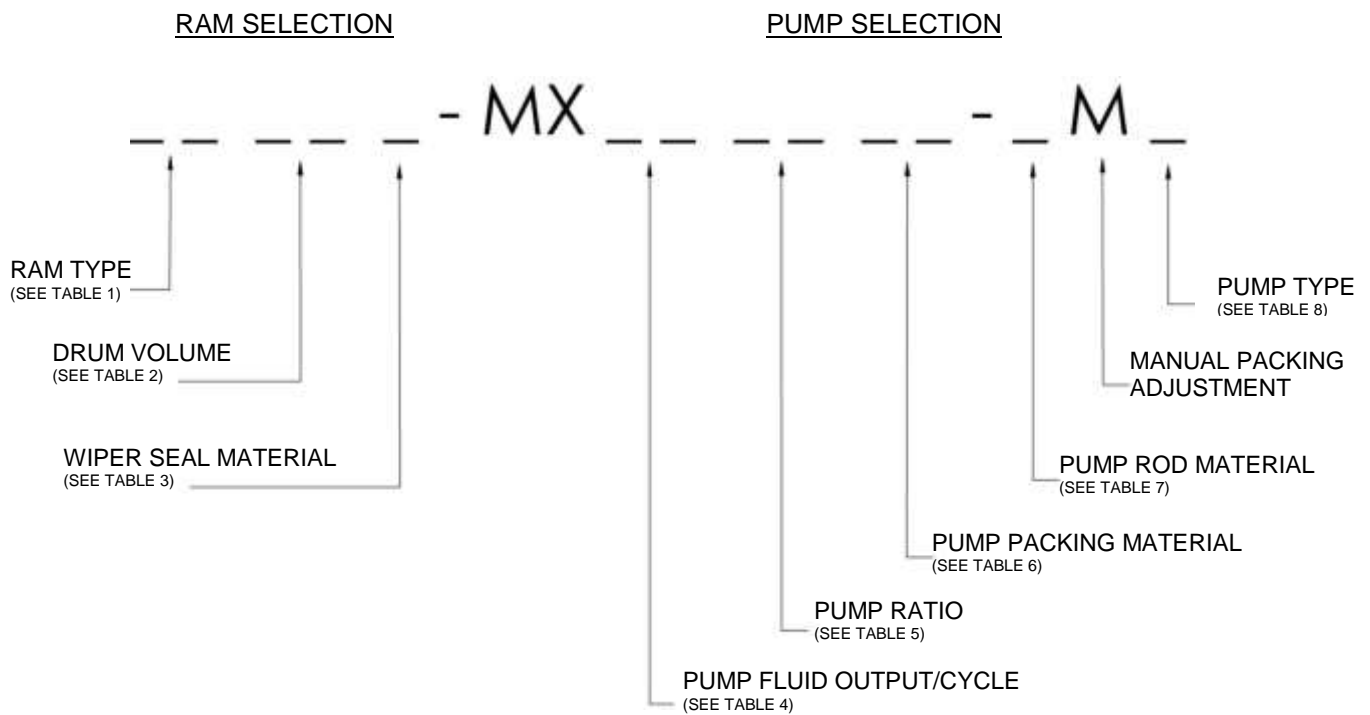

TYPICAL EXAMPLE:

- **DRX205E – MX86023PU – SMX**

TABLE 1	
CODE	DESCRIPTION
DRX	Dual Post Ram Extreme Duty (Ø160mm)

TABLE 2		
CODE	DESCRIPTION	Table 1 Ref.
		DRX
60	60L / 15 Gallon Drum	✓
205	205L / 55 Gallon Drum	✓

TABLE 3			
CODE	DESCRIPTION	Table 2 Ref.	
		60	205
E	EPDM	✓	✓

TABLE 4 - Chop Check Pumps			
CODE	DESCRIPTION	DRX Rams	
		60	205
115	115 cc/cycle		✓
200	200 cc/cycle	✓	✓
420	420 cc/cycle		✓
860	860 cc/cycle		✓

TABLE 5 - Chop Check Pumps					
CODE	DESCRIPTION	Table 4 Ref.			
		115	200	420	860
15	15:1 Pump Ratio				✓
23	23:1 Pump Ratio				✓
30	30:1 Pump Ratio			✓	
39	39:1 Pump Ratio (DRX205 Only)		✓		
43	43:1 Pump Ratio	✓			
46	46:1 Pump Ratio			✓	
66	66:1 Pump Ratio		✓		
68	68:1 Pump Ratio	✓			

TABLE 6	
CODE	DESCRIPTION
PU	PTFE & UHMWPE

TABLE 7					
CODE	DESCRIPTION	Table 4 Ref.			
		115	200	420	860
C	Nitrided Carbon Steel		✓	✓	✓
S	Ceramic Coated Stainless Steel	✓	✓	✓	✓

TABLE 8					
CODE	DESCRIPTION	Table 4 Ref.			
		115	200	420	860
X	Ram Mount Chop Check Pump	✓	✓	✓	✓

DRX60

104156 - Installation

The ram plate base should be mounted on a stable and level floor.

The standard ram plate has 4 off - holes Ø 21 mm to enable the base to be securely fixed to the floor. Suitable floor fixing 'rawbolts' should be used which are designed to suit the floor material.

Base plate = 930mm x 480mm. Mounting holes = 1040mm x 400mm

A compressed air supply is connected to the 1/2" BSP F connection to control the lift and lowering of the air cylinders and supply the pump.

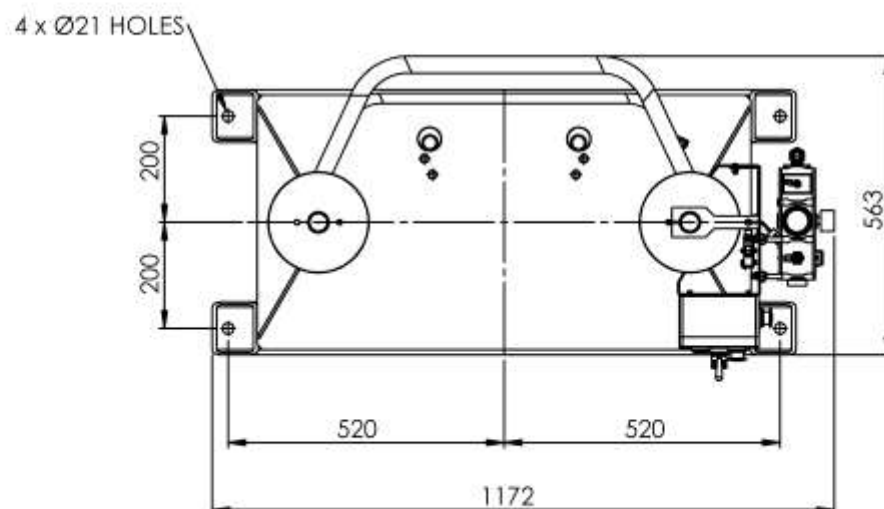
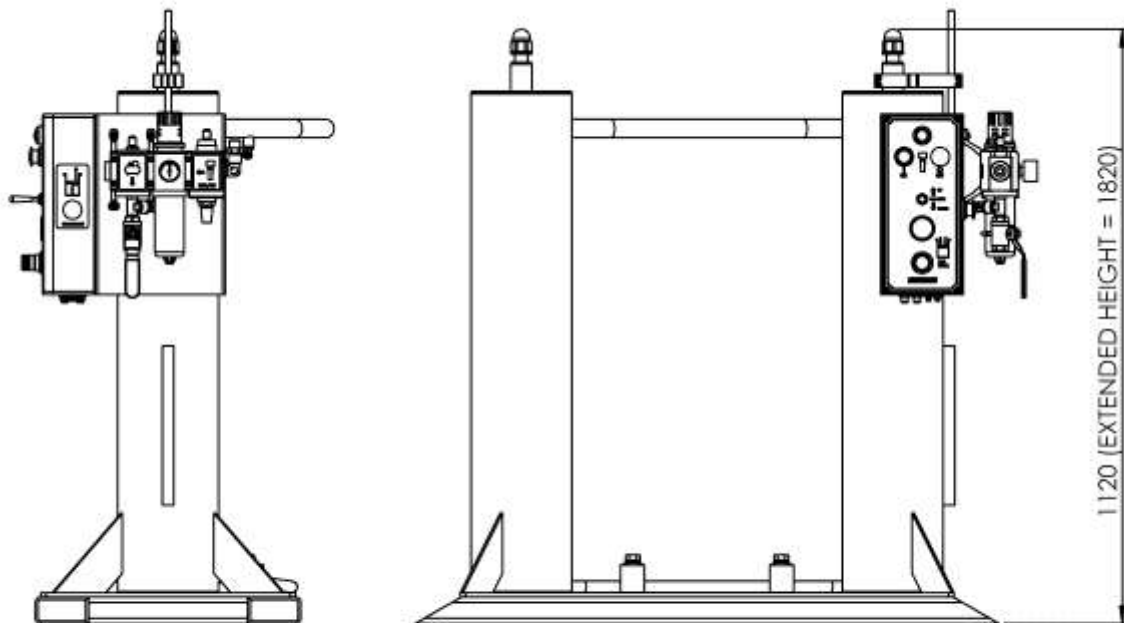

Operation Instructions

Setting up ram trip valve

1. Make sure that the air to the pump is turned off by fully unwinding the regulator on 104098.
2. Press the on (green) button on 104098. This indicator should now be green.
3. Place an empty drum under the ram plate. With the ram pressure set at 2 Bar lower the ram into the drum until it has made contact with the bottom of the drum. When the valve is tripped the indicator will switch to red (meaning pump off).
4. Set the trip valve so that it has just tripped, by between 5 – 10mm. Test this a number of times to make sure that the valve trips before the ram plate contacts the bottom of the drum.
5. If different drums are to be used then checks should be made to make sure that the valve is operated.

Setting up ram force for different materials

1. Place a fresh drum of material underneath the ram plate.
2. Open the ram plate priming assembly.
3. Set the ram force to 2 Bar.
4. Select the Up / Stop / Down controller to **Down**.
5. A slight delay will occur before the ram starts to move. This is to allow air to exhaust from the 'up' side of the cylinder.
6. Check that the ram is going down squarely into the drum.
7. As the ram plate goes into the drum, air will be pushed out of the vent.
8. When material starts to come out of the vent, close the primer screw assembly.
9. Operate pump and system under normal operating conditions. At all times checking the pump for cavitation. On very thick, non-flowing materials pressures up to 5 Bar may be required, in order to prime the pump correctly. However high ram pressures must not be used on light free-flowing materials as leaks around the ram seals could develop.
10. When the air pressure is set use the "Raising the ram from a drum" procedure, and remove drum from the unit.
11. It is now time to set the speed of the "Up and Down" motion of the ram unit.
12. Remove the cover from the 104097 control box mounted on the ram unit leaving the hoses connected. Operate the "up / down" valve and at the same time screw in or out the control valve (silencer / speed controller). The motion needs to slow enough so that removing an empty drum can be one smooth operation, about 1 full stroke in 30 seconds.
13. Do not use the pressure regulator to control the speed of the unit, as it will give an uneven movement.

Operation

Lowering the ram onto material

1. Place a fresh drum of material underneath the ram plate.
2. Open the ram primer screw assembly.
3. Select the Up / Stop / Down controller to **down**.
4. Make sure that the ram force is to the correct pressure. (see Setting up ram pressure)
5. A slight delay will occur before the ram starts to move. This is to allow air to exhaust from the 'up' side of the cylinders.
6. Check that the ram is going down squarely into the drum.
7. As the ram plate goes into the drum, air will be pushed out of the vent.
8. When material starts to come out of the vent, close the primer screw assembly.
9. The ram is now ready to use.

Raising the ram from a drum

1. Make sure that the pump is turned **off**, air pressure relieved and pump pressure also relieved.
2. Select the Up / Stop / Down controller to **up**.
3. As the ram starts to move inject small bursts of compressed air by pressing the Drum Release button mounted on the side of the unit. This will slowly push the drum off the ram.
4. Be very carefully not to inject too much air, as air can escape between the ram plate seal and the drum. This is not dangerous but can make an unnecessary mess that requires cleaning.

DRX60 Outfit Assemblies

Parts List - DRX60 Ram Unit Outfits				
Item	Part No.	Description	Qty.	Remarks
1	AX260L-7R	AX260L-7R AIR MOTOR	1	
2	FX200PU-CMX	FX200PU-CMX FLUID SECTION	1	CMX MODEL
2	FX200PU-SMX	FX200PU-SMX FLUID SECTION	1	SMX MODEL
3	0115-010445	MOTOR ROD SPLIT COLLAR	1	
4	0115-010447	PUMP ROD QD ADAPTER	1	
5	0115-010448	SPLIT COLLAR RETAINER	1	
6	0115-010450	HAIRPIN CLIP	1	
7	104156	DRX60 RAM UNIT ASSEMBLY	1	
8	164838	No 2 x 4.75 RIVET	2	
9	165097	M16 PLAIN WASHER PLATED	3	
10	165139	M20 SPRING WASHER - PLATED	3	
11	177040	M20 DOME NUT - PLATED	3	
12	177052	M16 DOME NUT - PLATED	3	
13	193540	NAMEPLATE	1	
14	193543	COVER CLIP	1	
15	193546	SPLIT GUARD	2	
16	194458	MOUNTING PLATE	1	
17	194459	AIR MOTOR TIE ROD	3	
18	194460	PUMP TIE ROD	3	
19	194461	DRX60 RAM PLATE ASSEMBLY	1	
20	20-6832	M16 LOCK WASHER	6	
21	20-6834	M16 HEX NUT	3	
22	193999	CONNECTION KIT - NOT SHOWN	1	

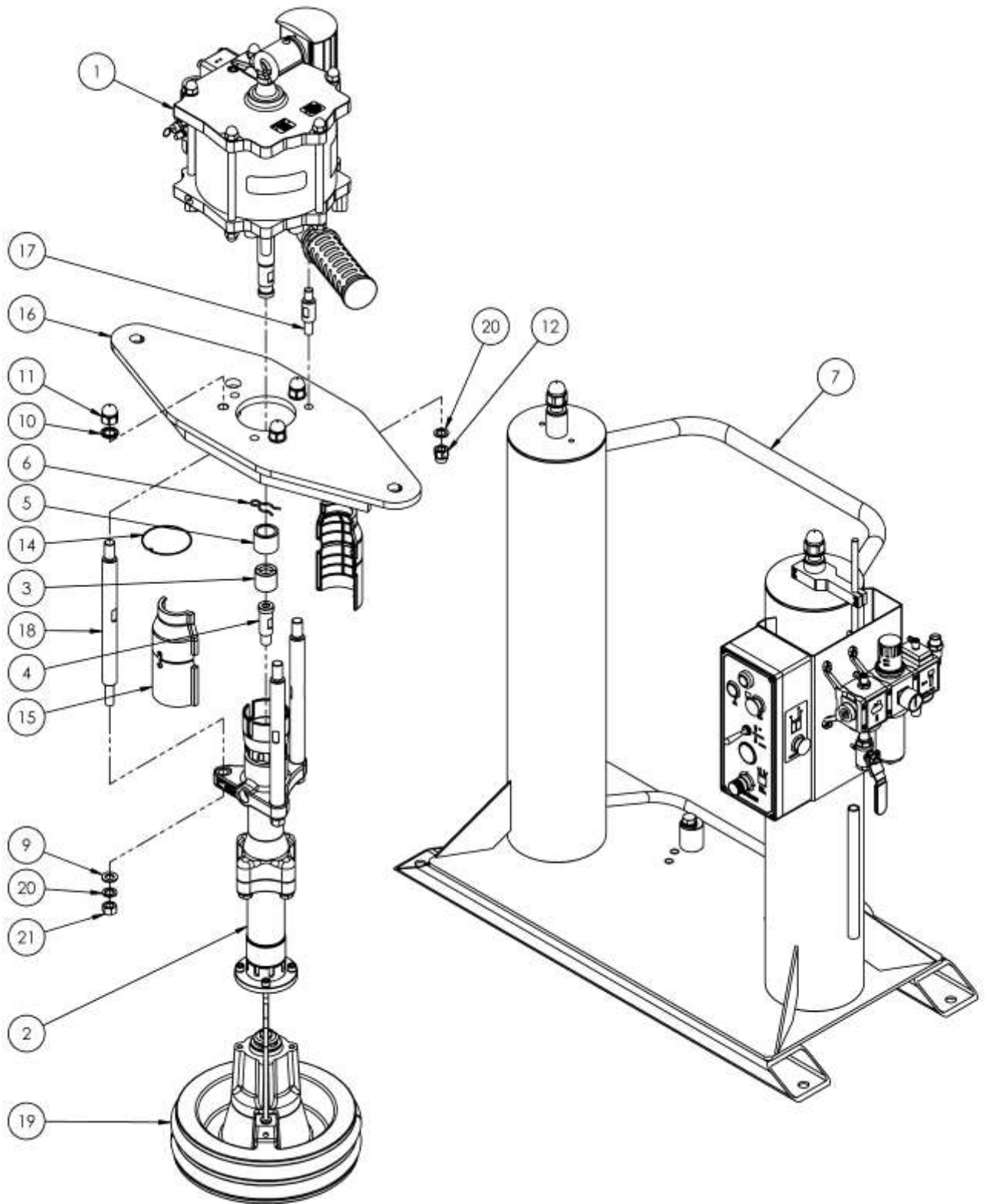

NOTES

Ram Unit Parts Lists

Parts List - 104156 Ram Unit				
Item	Part No.	Description	Qty.	Remarks
1	104097	RAM CONTROL BOX	1	
2	104098	RAM AIR REG SETUP	1	
3	104160	DRX TRIP ROD KIT	1	
4	165100	M16 SPRING WASHER	2	
5	165373	M16 x 70 HEX HD BOLT	2	
6	177041	M4 x 45 SOCKET HD CAP SCREW	4	
7	177048	M24 SAFETY WASHER	2	
8	177057	M24 DOME NUT	2	
9	193943	1/4" Ø6 PUSH IN ELBOW	2	
10	194013	DRUM STOP	2	
11	194392	DRX60 BARE RAM UNIT	1	
12	DVX-30	M4 NYLOC NUT	4	
13	DVX-31	M4 WASHER	4	
14	170244	Ø6 x 4 PU HOSE - BLACK	2m	NOT SHOWN
15	170245	Ø4 x 2.5 PU HOSE - BLACK	2m	NOT SHOWN

Assembly Drawing

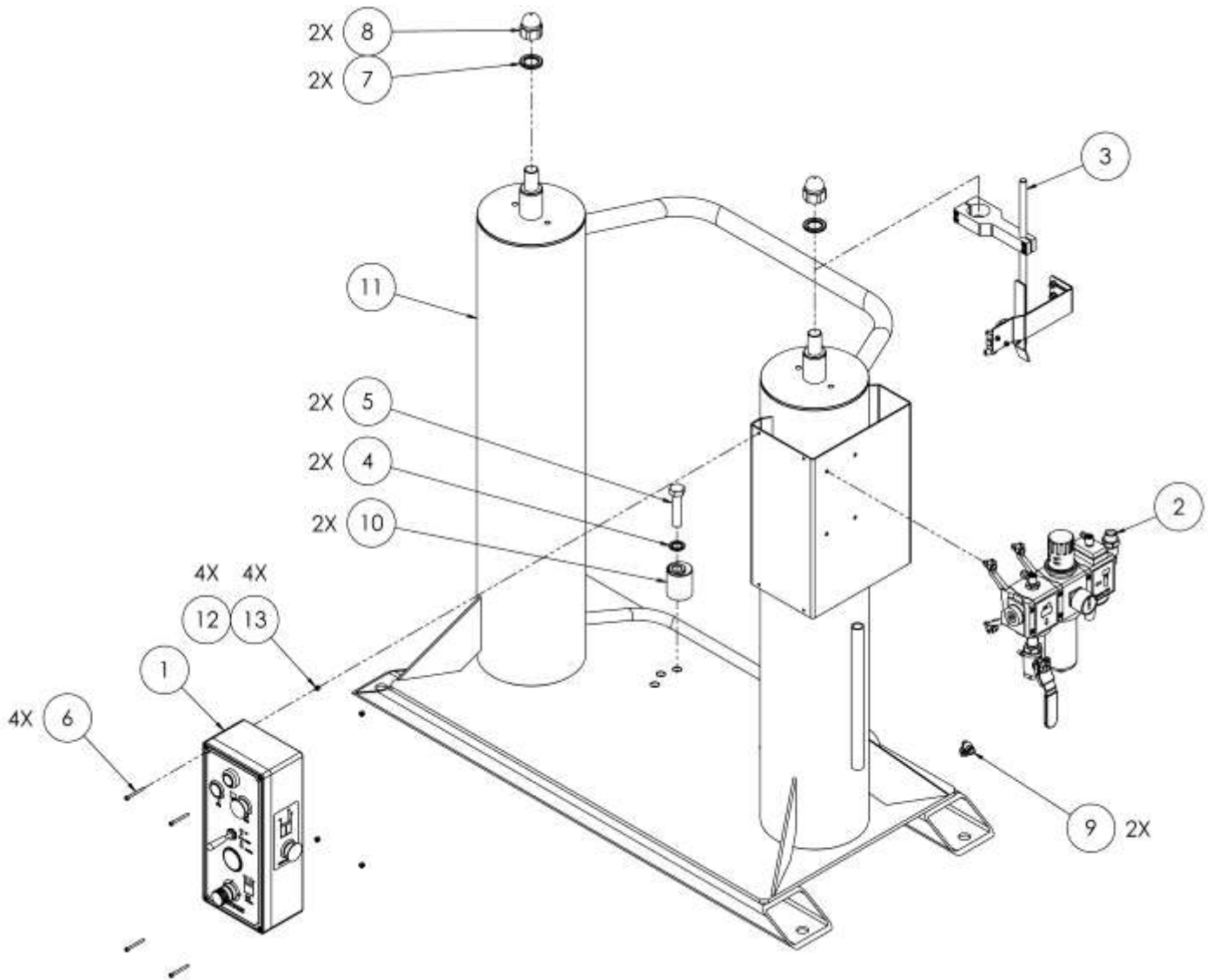

DRX205

104157 - Installation

The ram plate base should be mounted on a stable and level floor.

The standard ram plate has 4 off - holes \varnothing 21 mm to enable the base to be securely fixed to the floor. Suitable floor fixing 'rawbolts' should be used which are designed to suit the floor material.

Base plate = 1150mm x 680mm. Mounting holes = 1290mm x 600mm

A compressed air supply is connected to the 1/2" BSP F connection to control the lift and lowering of the air cylinders and supply the pump.

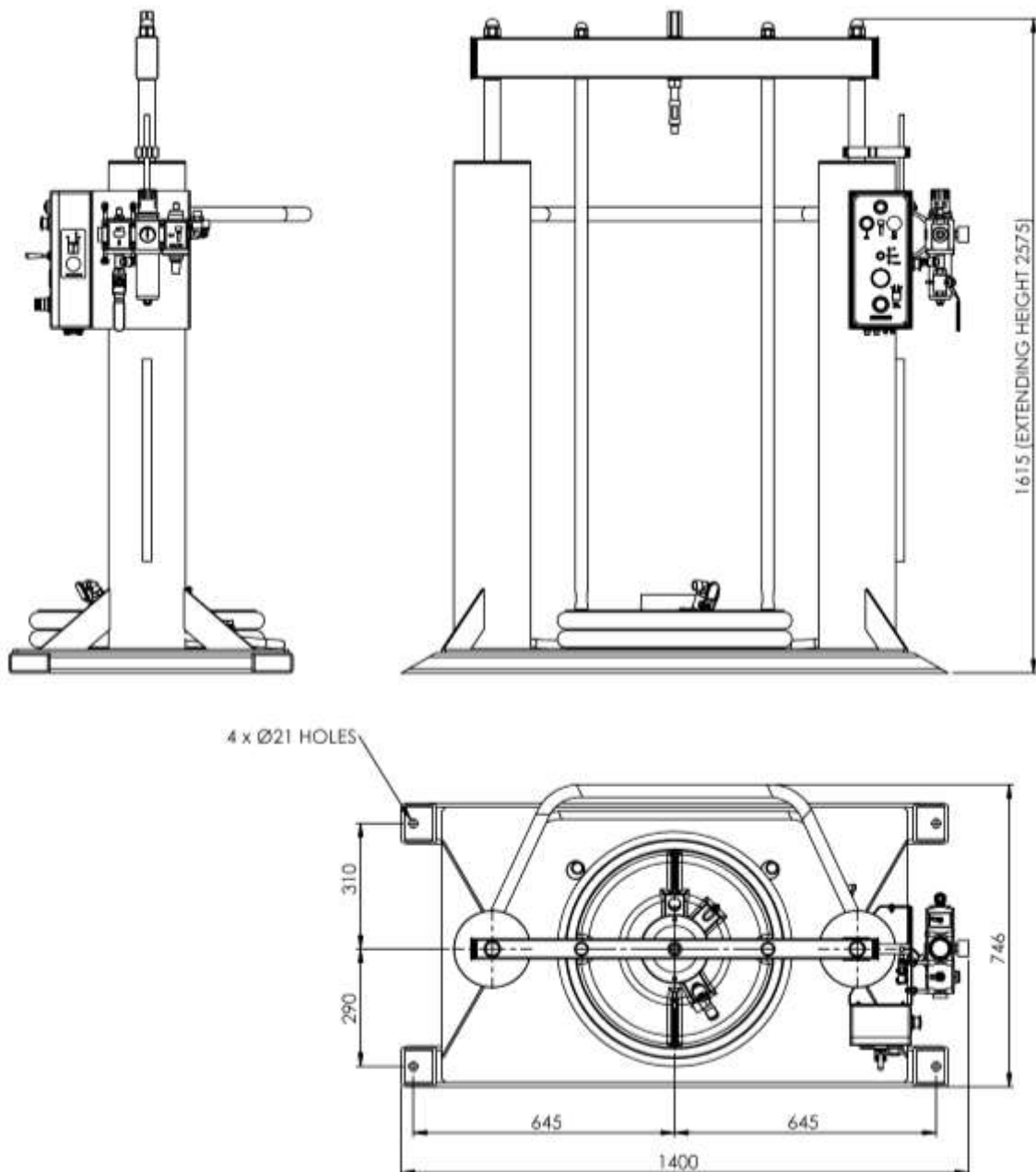

DR205 Outfit Assemblies

Parts List - DRX205 Ram Unit Outfits				
Item	Part No.	Description	Qty.	Remarks
1	104157	DRX205E RAM ASSEMBLY	1	
2	MX.....	PUMP ASSEMBLY – SEE SELECTION TABLE	1	
3	194000	CONNECTION KIT – NOT SHOWN	1	MX200 MODELS
4	194001	CONNECTION KIT – NOT SHOWN	1	MX420/860 MODELS
5	194465	CONNECTION KIT – NOT SHOWN	1	MX115 MODELS

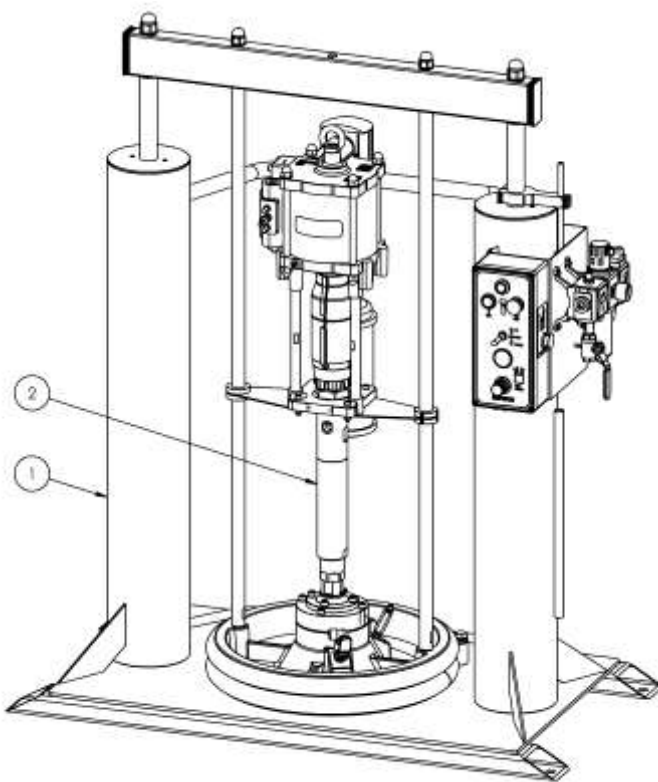

MX115 MODELS

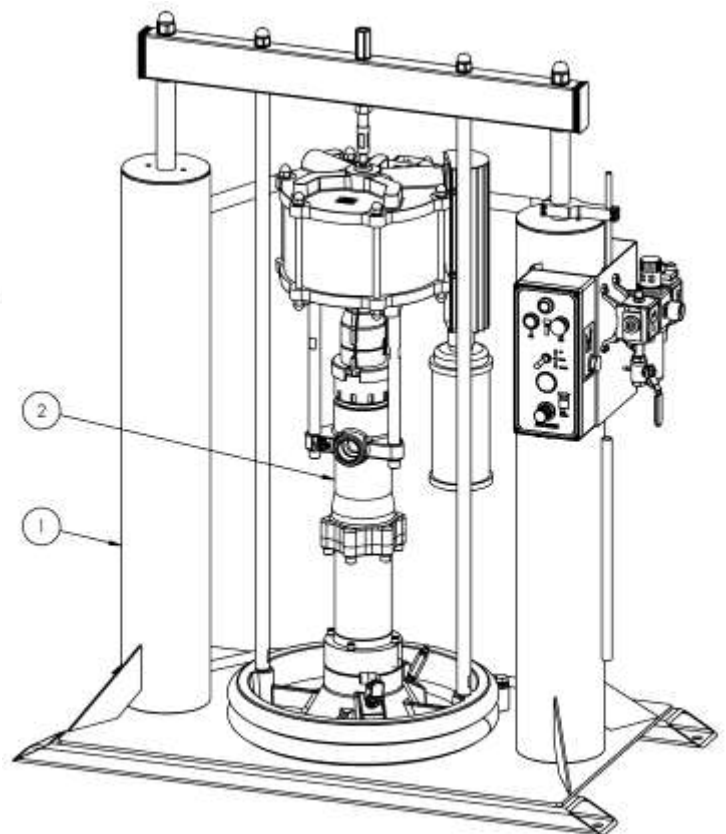

MX420/860 MODELS

Ram Unit Parts Lists

Parts List - 104157 Ram Unit				
Item	Part No.	Description	Qty.	Remarks
1	104097	RAM CONTROL BOX	1	
2	104098	RAM AIR REG SETUP	1	
3	104160	DRX TRIP ROD KIT	1	
4	165100	M16 SPRING WASHER	2	
5	165139	M20 SPRING WASHER	2	
6	165373	M16 x 70 HEX HED BOLT	2	
7	177034	M20 HEX NUT - PLATED	1	
8	177035	M20 STUD CONNECTOR	1	
9	177041	M4 x 45 SOCKET HD CAP SCREW	4	
10	193765	SUPPORT BAR	1	
11	193943	1/4" Ø6 PUSH IN ELBOW	2	
12	194013	DRUM STOP	2	
13	194295	205L FOLLOWER PLATE ASSEMBLY	1	
14	194393	DRX205 BARE RAM UNIT	1	
15	DVX-30	M4 NYLOC NUT	4	
16	DVX-31	M4 WASHER	4	
17	170244	Ø6 x 4 PU HOSE - BLACK	3M	NOT SHOWN
18	170245	Ø4 x 2.5 PU HOSE - BLACK	2M	NOT SHOWN

Assembly Drawing

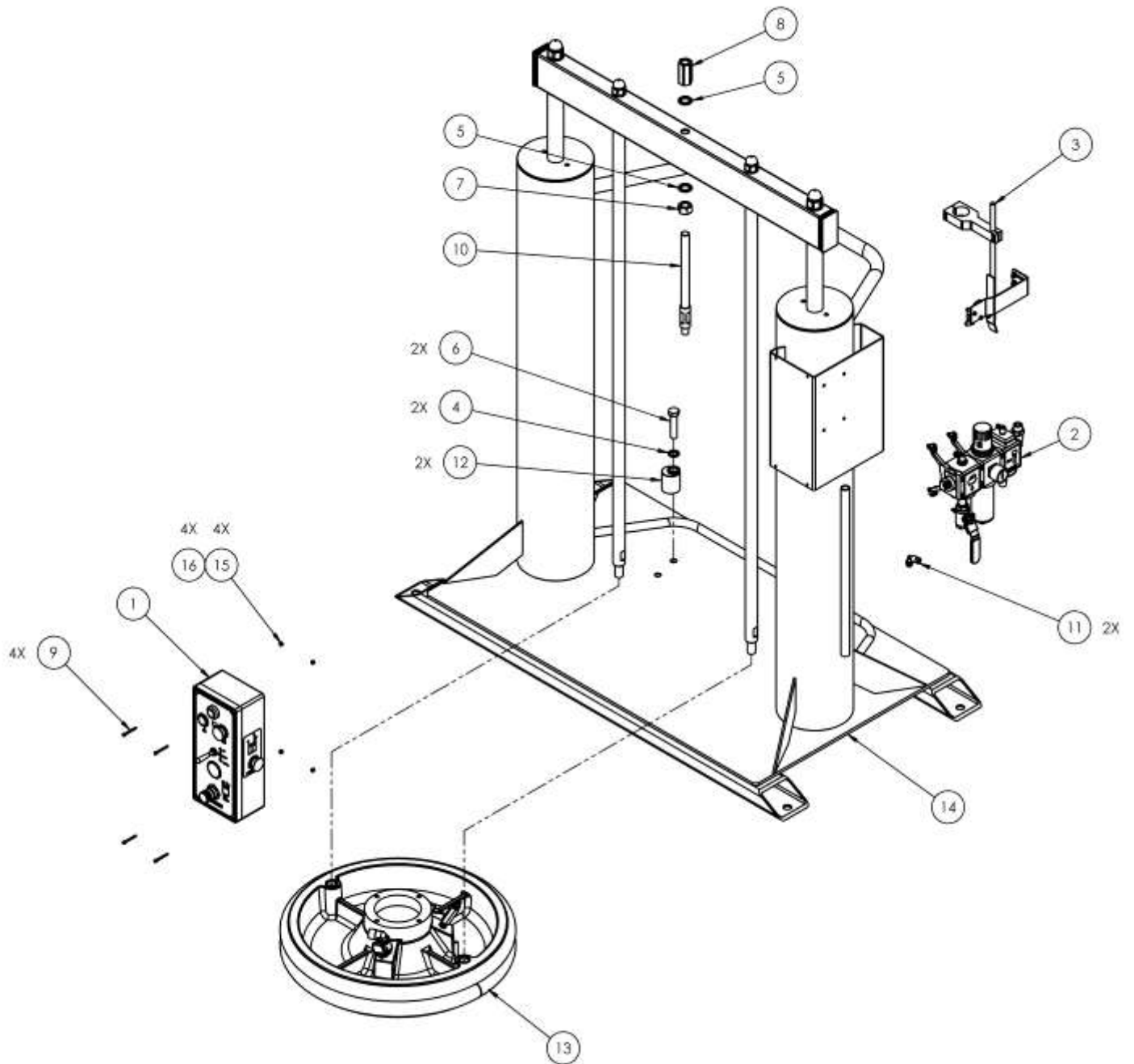

104097 Ram Control Box Details

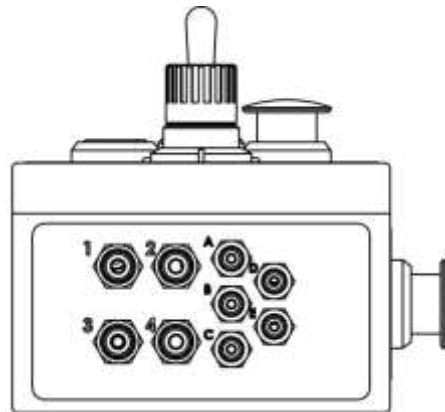
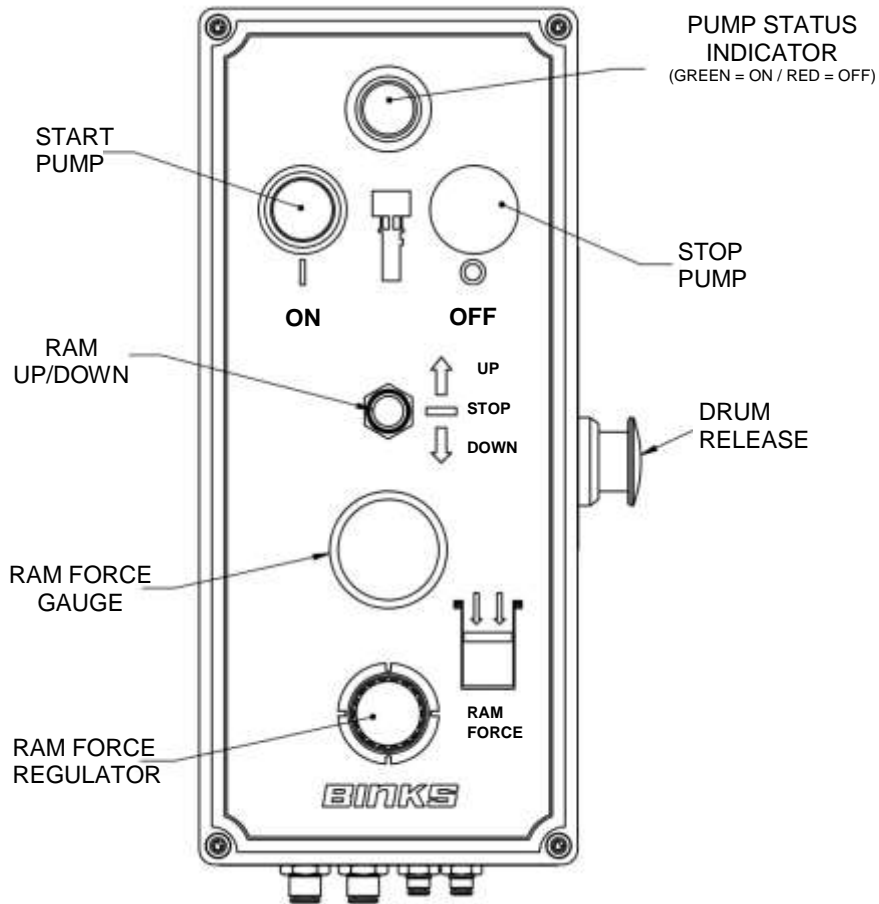

Ø6mm PUSH IN

- 1 = MAINS AIR INLET
- 2 = RAM UP
- 3 = RAM DOWN
- 4 = DRUM RELEASE

Ø4mm PUSH IN

- A = MAINS AIR TO TRIP ROD
- B = TRIP ROD SIGNAL
- C = PUMP SHUT OFF SIGNAL

WHEN LINKED TO AUTOCHANGEOVER

- D = DRUM EMPTY SIGNAL
- E = PUMP START SIGNAL

104098 Air Regulator Unit

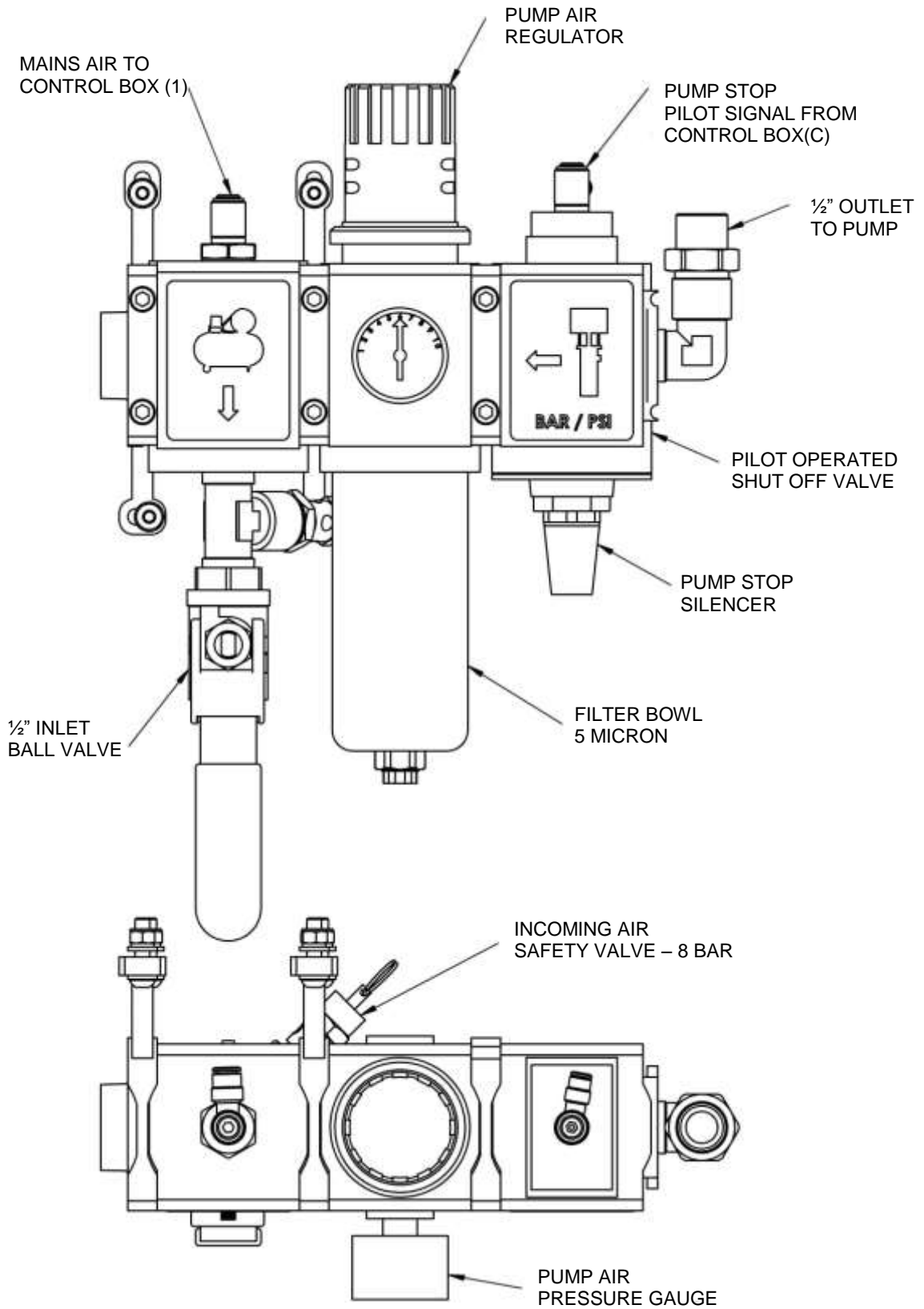

Parts List - 104160 Trip Rod Assembly				
Item	Part No.	Description	Qty.	Remarks
1	0115-010211	M6 NYLOC NUT	2	
2	163952	M6 x 20 CAP HD SCREW	2	
3	165129	M6 WASHER	2	
4	177031	M6 x 16 BUTTON HEAD SCREW	2	
5	177066	M6 x 50 SOCKET HD CAPSCREW	2	
6	192799	VENT PLUG	1	
7	193902	TRIP ROD ASSEMBLY	1	
8	193907	TRIP ROD 3/2 VALVE	1	#
9	193908	1/8" Ø4 PUSH IN ELBOW	2	
10	194474	VALVE BRACKET	1	
11	194475	DRX TRIP ROD CLAMP	1	
12	DVX-27	M4x25 CAP HEAD SCREW	2	
13	DVX-30	M4 NYLOC NUT	2	
14	DVX-31	M4 WASHER	4	

- Recommended spares for 104160

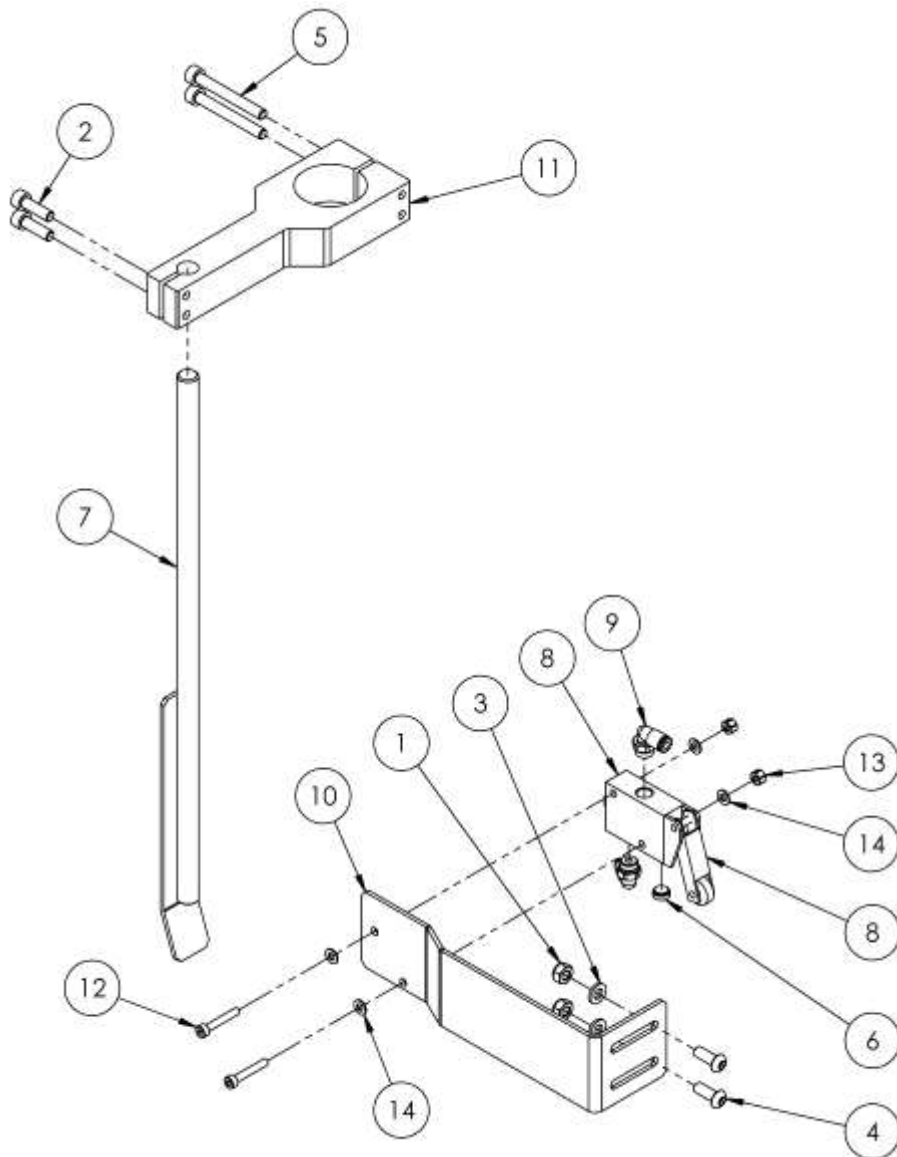

Parts List - 194461 Ram Plate 60L / 15G				
Item	Part No.	Description	Qty.	Remarks
1	181672	3/4" STRAP BUCKLE	4	
2	193754	PRIMER SCREW ASSEMBLY	1	
3	193768	1/4" NON RETURN VALVE	1	
4	193769	1/4" - Ø6 PUSH IN STRAIGHT	1	
5	193948	1/4" MALE - 1/4" MALE NIPPLE	1	
6	194297	DRX60 FOLLOWER PLATE MACHINING	1	
7	194466	3/4" STRAPPING - 1.3M LONG	2	
8	194467	WIPER SEAL - EPDM	2	

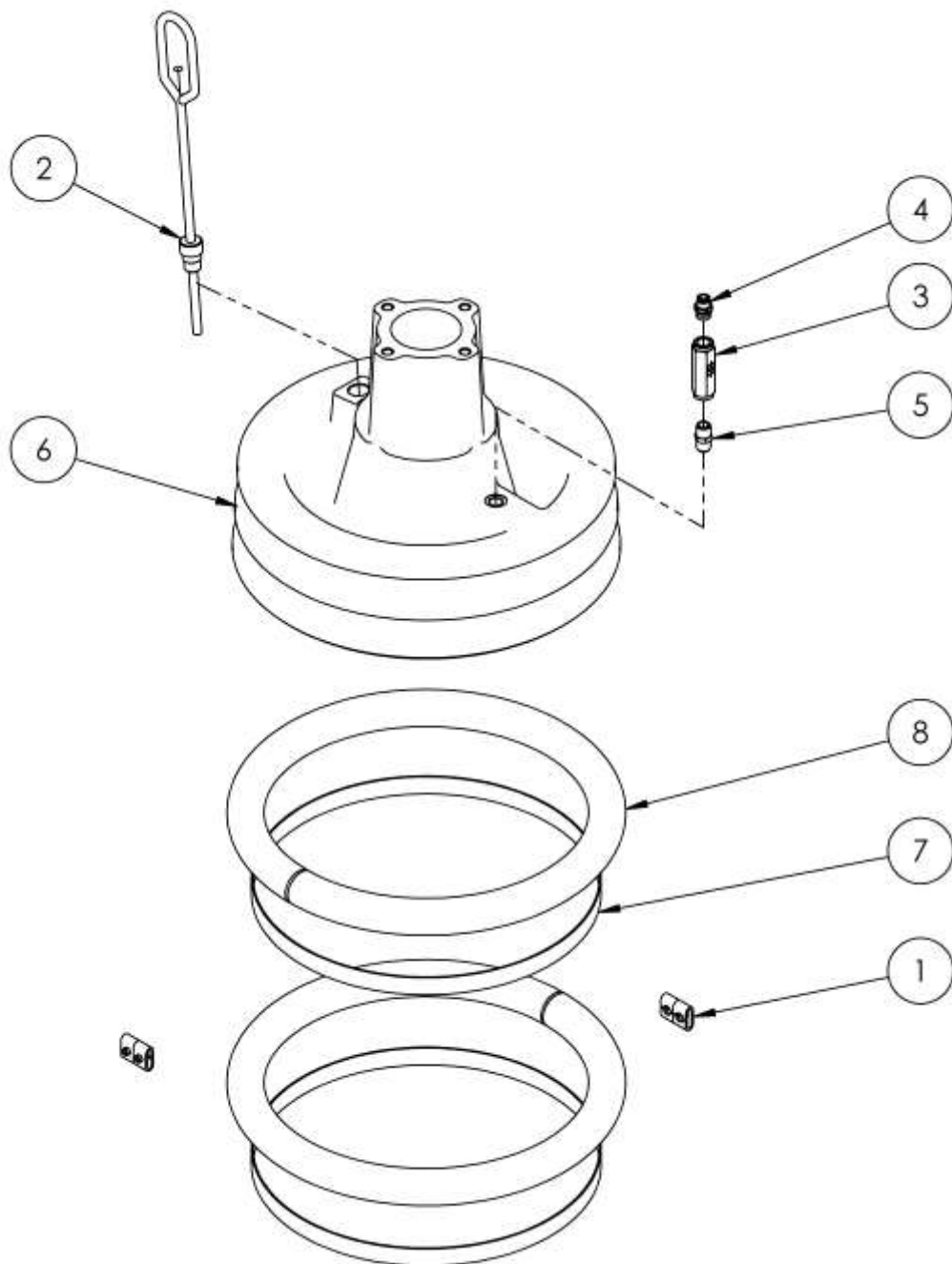

Parts List - 194295 Ram Plate 205L / 55G				
Item	Part No.	Description	Qty.	Remarks
1	181672	3/4" STRAP BUCKLE	4	
2	193768	1/4" NON RETURN VALVE	1	
3	193769	1/4" - Ø6 PUSH IN STRAIGHT	1	
4	193944	1/2" PLATED BRASS BALL VALVE	1	
5	193945	1/2" BSPT - 1/2" BSPT NIPPLE	1	
6	193946	1/2" MALE - 1/2" FEMALE ELBOW	1	
7	193948	1/4" MALE - 1/4" MALE NIPPLE	1	
8	194296	3/4" PLUG	1	
9	202522	3/4" STRAPPING - 2.3M LONG	2	
10	205027	205L RAM PLATE MACHINING	1	
11	207064	RAM SEAL	2	

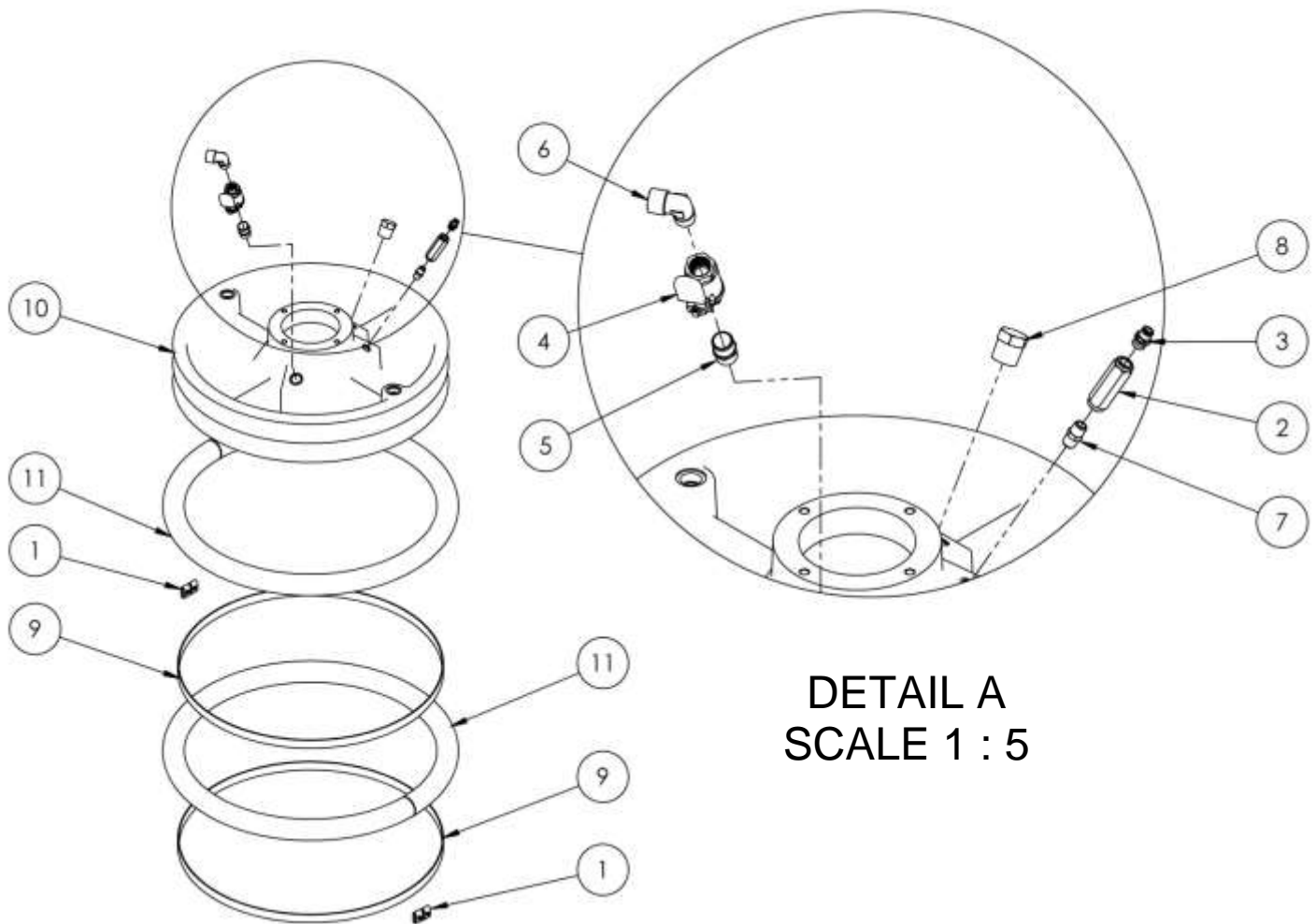

DETAIL A
SCALE 1 : 5

Accessories			
Item	Part No.	Description	Remarks
1	104099	Auto Change Over Panel	To Automatically change over to a Standby Ram Unit when the Duty Ram Unit is empty (Bottom Position)
2	0110-009130	High Pressure Filter (100 Mesh)	0110-009131 – 50 Mesh 0110-009133 – 150 Mesh 0110-009134 – 200 Mesh
3	0114-011760	High Pressure Filter (100 Mesh) (500 Bar Max.)	0114-014917 – 30 Mesh 0114-014886 – 50 Mesh 0114-014884 – 70 Mesh 0114-014883 – 100 Mesh 0114-014882 – 150 Mesh 0114-014881 – 200 Mesh
5	0114-016099	Pump Lubrication	Water Based – 0.25L
6	0114-016100	Pump Lubrication	Solvent Based – 0.25L
7	0114-014871	Pump Lubrication	Water Based – 0.5L
8	0114-009433	Pump Lubrication	Solvent Based – 0.5L
9	107866	Filter Housing St St	191833 – 200 Micron Element St St 191834 – 400 Micron Element St St 192523 – 600 Micron Element St St 192524 – 1200 Micron Element St St
10	107867	Filter Housing Carbon St	
11	107876	Twin Filter Housing Assembly St St	Filter Element to be Specified Separately
12	107877	Twin Filter Housing Assembly Carbon St	Filter Element to be Specified Separately

# Spare Parts For – (DRX60) 104156 Ram Unit				
Item	Part No.	Description	Qty	Remarks
1	194467	Wiper Seal - EPDM	2	
2	194466	Strapping	2	
3	181672	Strap buckle	4	
4	250725	Ram Cylinder Seal Kit	2	1 Per Cylinder
5	193768	¼" Non Return Valve	1	
6	193769	¼" – Ø6 Push In Straight	1	
7	193943	¼" – Ø6 Push In Elbow	2	
8	170244	Ø6 x 4 PU Hose – Black	3m	
9	170245	Ø4 x 2.5 PU Hose - Black	2m	
10	193948	¼" Male – ¼" Male Nipple	1	

# Spare Parts For – (DRX205) 104157 Ram Unit				
Item	Part No.	Description	Qty	Remarks
1	207064	Wiper Seal - EPDM	2	
2	202522	Strapping	2	
3	181672	Strap buckle	4	
4	193768	¼" Non Return Valve	1	
5	193769	¼" – Ø6 Push In Straight	1	
6	193943	¼" – Ø6 Push In Elbow	2	
7	193948	¼" Male – ¼" Male Nipple	1	
8	170244	Ø6 x 4 PU Hose – Black	3m	
9	170245	Ø4 x 2.5 PU Hose - Black	2m	
10	250725	Ram Cylinder Seal Kit	2	1 Per Cylinder

# Spare Parts For - 104160 Trip Valve Kit				
Item	Part No.	Description	Qty	Remarks
1	193907	3/2 Trip Valve	1	

Cylinder Service Reference – Spares Kit 250725

CYLINDER ROD HOUSING ASSEMBLY

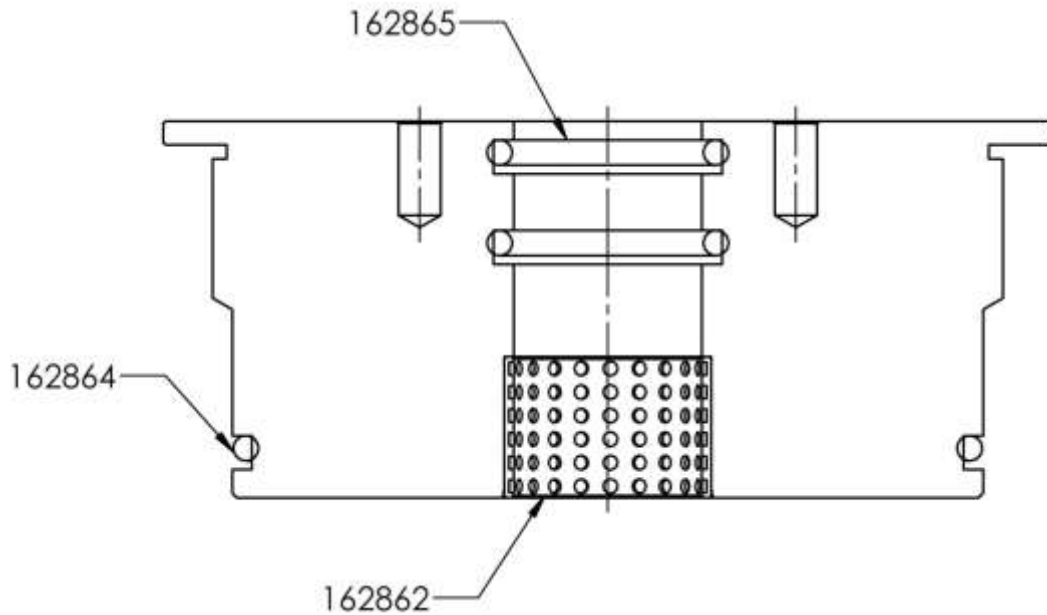

RAM PISTON

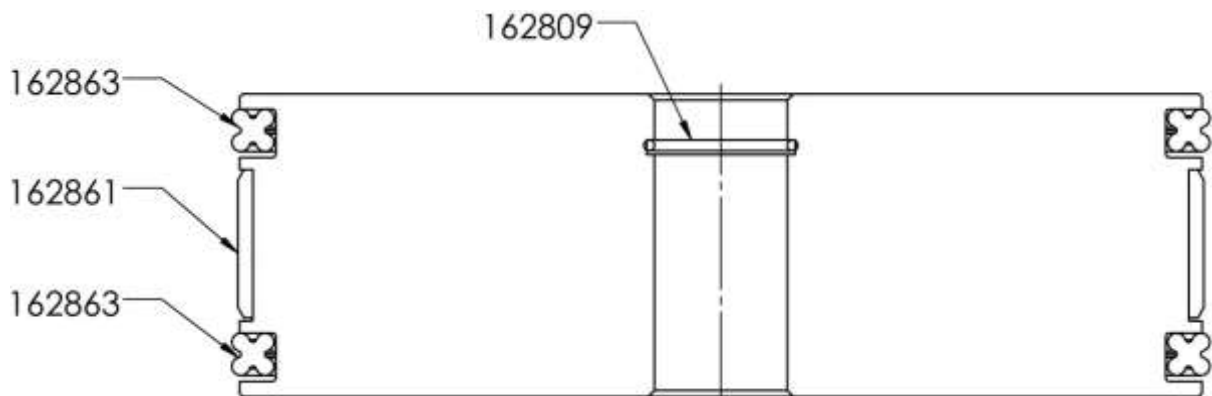

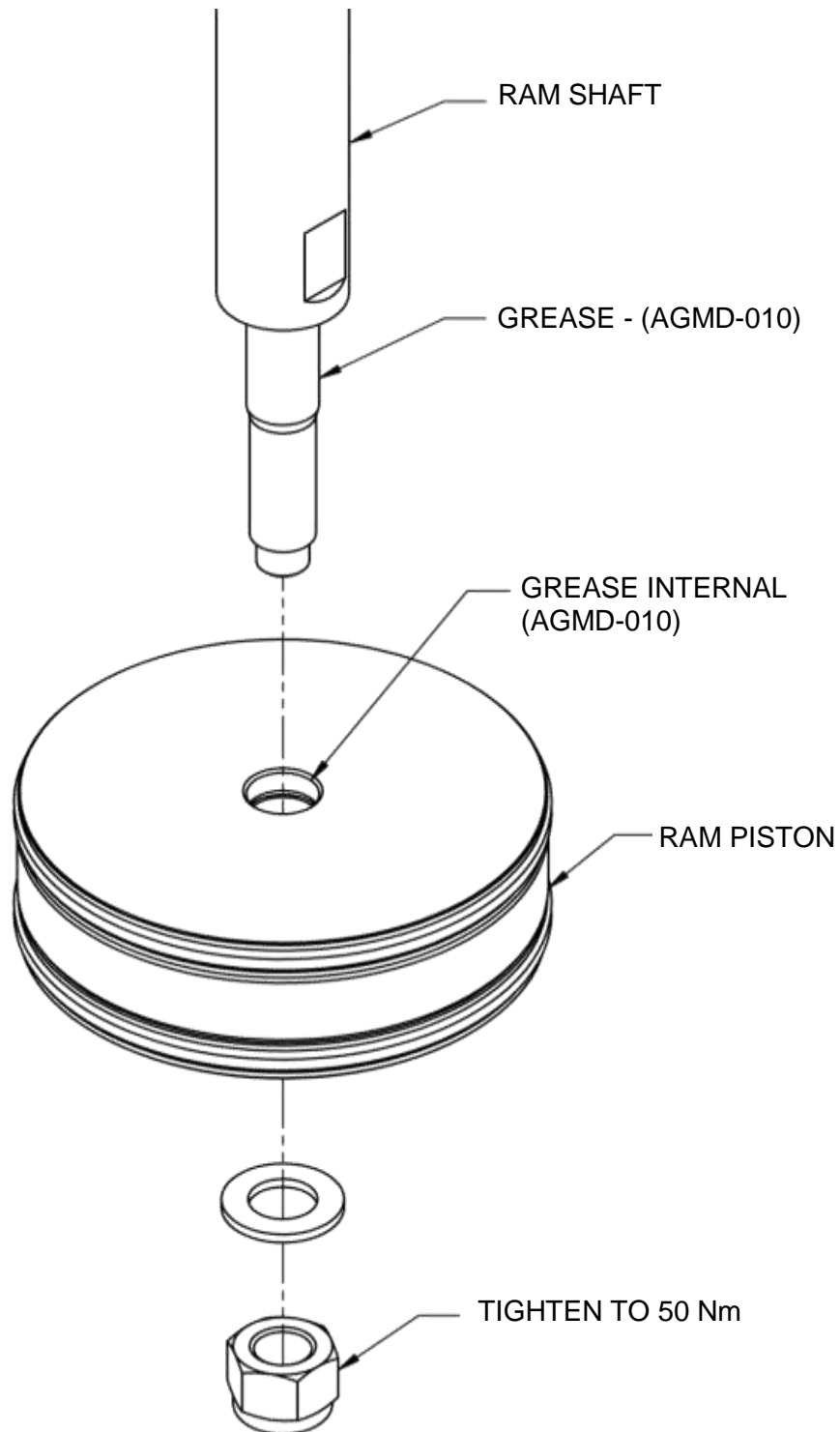



Justus-von-Liebig-Straße 31, 63128 Dietzenbach. DE
Tel. +49 (0) 6074 403 1 Fax. +49 (0) 607 403 300
General e-mail: info@carlisleleft.eu

Ringwood Road, Bournemouth, Dorset BH11 9LH. UK
Tel. +44 (0)1202 571 111 Fax. +44 (0)1202 573 488
General e-mail: info@carlisleleft.eu

163-171, Av. des Auréats, 26014 Valence cedex. FR
Téléphone : +33 (0) 4 75 75 27 53 Télécopie: +33 (0) 4 75 75 27 79
General e-mail: info@carlisleleft.eu

USA Canada Customer Service

195 Internationale Blvd.
Glendale Height,IL 60139
630-237-5000

Toll Free Customer Service and
Technical Support 800-992-4657
Toll Free Facsimile 800-246-5732